



# Champion® Residential Heat Pumps

## HMH7 Horizontal Discharge Heat Pump

Up to 18 SEER  
Inverter Drive

### Exceptional flexibility. Exceptional performance. Exceptional features.

The Champion® HMH7 Heat Pump is designed to provide all the comfort and technology of a mid-tier efficiency unit at the cost of a base-tier vertical unit for residential customers. It's an ideal solution for homes in temperate regions that require a compact design and comes in several models and tonnages with flexible installation options and innovative features.

### Benefits of side discharge

- Up to 18 SEER/10.5 HSPF for high-quality, efficient comfort
- 40% smaller footprint compared to traditional vertical discharge units
- 36% quieter operating sound, as low as 54 dBA
- Safety certified by ETL and performance certified to ANSI/AHRI Standard 210/240 in accordance with the Unitary Small Equipment certification program

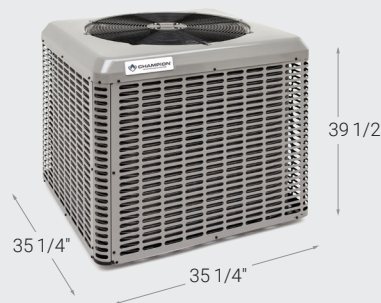

Traditional Inverter H/P



HMH7 Inverter H/P



**CHAMPION®**  
HEATING AND COOLING

VISIT [CHAMPIONHOMECOMFORT.COM](http://CHAMPIONHOMECOMFORT.COM) FOR MORE INFORMATION

**Efficient operation**

- Inverter system and modulating technology smoothly ramp up operation and continuously adjust, avoiding spikes in energy use while helping to increase overall system longevity and reducing the homeowner’s energy bills.
- Available in 2, 3, 4 and 5 ton options to ensure a precise, effective solution for your customer’s needs.

**Exact comfort**

- Innovative fan design creates less vibration and provides quieter operation, with sound output as low as a typical dishwasher at 54 dBA (36% lower sound levels than standard heat pump units).
- Modulating technology maintains exact temperatures by operating from 35–100% capacity, matching the precise degree of heating required.

**Easier installation**

- 40% more compact than standard heat pump units – ideal for high-density areas.
- Includes a simple kit (relay, wiring and bi-flow filter/dryer) for standard installation with conventional equipment and devices.
- No unique installation procedures required.
- Long line set length (up to 246 ft) for optimal configurability.
- Can be placed anywhere a vertical unit can, and often in places vertical units can’t fit, thanks to lot placement, clearance and set-back flexibility (figures 1 and 2).
- Designed to work with Champion® variable speed or standard ECM indoor air handling equipment, the HMH7 provides many system installation options.

**Quick service** – Routine maintenance is faster, thanks to easier access for service checks.

**Outstanding warranties** – HMH7 heat pumps come standard with a 10-year Compressor Limited Warranty, a 10-year Parts Limited Warranty and available extended warranties for up to a full system replacement (product registration required).

Figure 1: HMH7 Minimum Clearances

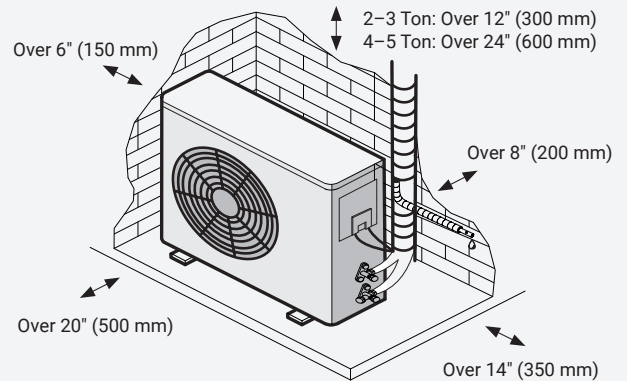
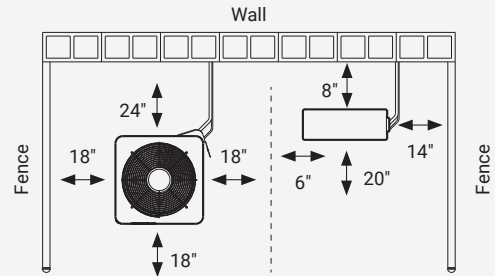

Figure 2: Traditional, Vertical Unit Minimum Clearances vs. HMH7 Minimum Clearances



**HMH7 Horizontal Discharge Heat Pumps**

Model	Tons	SEER	HSPF	Height (Inches)	Width (Inches)	Depth (Inches)	Operating Weight (Lbs)	Sound Range (dBA) Low–High*
HMH72B241S	2	17.5	9.0	26 3/8	33 7/8	12 1/4	112	54–65
HMH72B361S	3	18.0	10.5	33	37 3/8	13 3/8	155	56–68
HMH72B481S	4	18.0	9.5	54 5/8	37 3/8	13 3/8	227	62–69
HMH72B601S	5	17.0	10.0	54 5/8	37 3/8	13 3/8	251	62–73

Pair with Champion® AE high-efficiency air handlers, AVC air handler or CF/CU/CM evaporator coils.

\*High sound rated in accordance with AHRI Standard 270.

**Industry-leading warranties**



Product registration required.



Our network of SOURCE 1™ supply centers provides easy access to genuine, factory-authorized service parts.

